

# DESIGN NOTES

## High Efficiency Adaptable Power Supply for XENPAK 10Gb/s Ethernet Transceivers – Design Note 295

Dongyan Zhou

### Introduction

The XENPAK Multisource Agreement (MSA) defines a fiber optic module that conforms to the 10Gb/s Ethernet standard specified by IEEE 802.3ae. These modules require an adaptable power supply rail (APS) that has a variable output voltage from 0.9V to 1.8V, generated from a 3.3V input. The LTC<sup>®</sup>1773 current mode synchronous buck regulator provides an efficient, cost effective and space saving APS solution that exceeds the MSA standard as well as other similar standards.

The LTC1773 has features that make it a good match for this application including its 0.8V reference and 2.65V minimum input voltage. The reference is  $\pm 1.5\%$  accurate over temperature which makes it easy to meet the  $\pm 4\%$  APS tolerance specified in the MSA. The operating frequency is internally set at 550kHz, allowing the use of small surface mount components. Synchronous rectification increases efficiency and eliminates the need for an external Schottky diode, saving additional cost and space.

Finally, the LTC1773 comes in a tiny 10-lead MSOP package, keeping the total board space for an entire APS solution under  $0.4\text{in}^2$ .

### Adaptable Power Supply

Figure 1 shows an efficient APS design using the LTC1773. The APS SENSE pin provides for Kelvin sensing to compensate for PCB and connector voltage drops. The resistor R1, on the module side, programs the APS voltage. Table 1 lists R1 resistor values and corresponding APS voltages. Although Table 1 shows values for 1% resistors, higher accuracy resistors can be used to provide additional tolerance margin. In this design, the output voltage is set a little higher than specified to compensate for the ground plane drop.

The R4 pull-up resistor sets the output voltage at 0V when the APS SENSE lead is open. If the APS SENSE lead connects before the APS OUT and GND leads, the

LTC and LT are registered trademarks of Linear Technology Corporation.

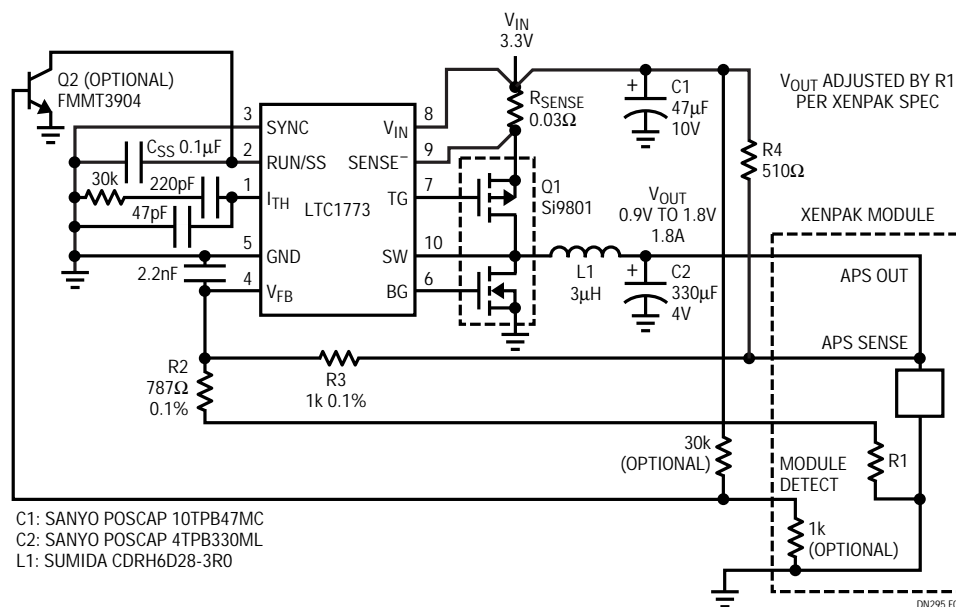

Figure 1. Adaptable Power Supply Using the LTC1773

**Table 1. APS Set Resistor Values**

V <sub>NOM</sub> (V)	R1 (Ω)
0.9	6810
1.0	3090
1.1	1820
1.2	1180
1.3	787
1.4	536
1.5	348
1.6	205
1.7	97.6
1.8	0

feedback pin of the LTC1773 is pulled low, resulting in an instantaneous high voltage from the APS. To prevent this, the APS OUT and GND leads are elongated in the XENPAK module pin description. If the APS SENSE lead is connected before the APS SET lead, the supply just defaults to the 0.8V feedback voltage. As an optional function, the MODULE DETECT pin can be used to turn on the APS. When the MODULE DETECT lead is open, the

RUN/SS pin is pulled low by Q2 to shut down the converter. When the MODULE DETECT lead is connected, Q2 is turned off by the 1k pull-down resistor. The RUN/SS pin is then released to enable the converter. The LTC1773 also provides a soft-start function with a ramp rate controlled by the value of the soft-start capacitor C<sub>SS</sub>. The sense resistor R<sub>SENSE</sub> sets an accurate current limit. The Si9801 complementary MOSFET saves cost and space.

Efficiency for this circuit peaks at 91% and stays above 78% across the output current and voltage range, as shown in Figure 2. Figure 3 shows the output voltage ripple measured at 15mV peak to peak (about 4.3mV<sub>RMS</sub>) on the host side, which is well below the 40mV<sub>RMS</sub> ripple requirement of the XENPAK MSA. The ripple measured at the input of the module is even lower due to the parasitic inductance and the input capacitor on the module.

**Conclusion**

The LTC1773 is a simple and efficient solution for XENPAK adaptable power supplies. A complete APS design requires few external components, saving space, cost and design time.

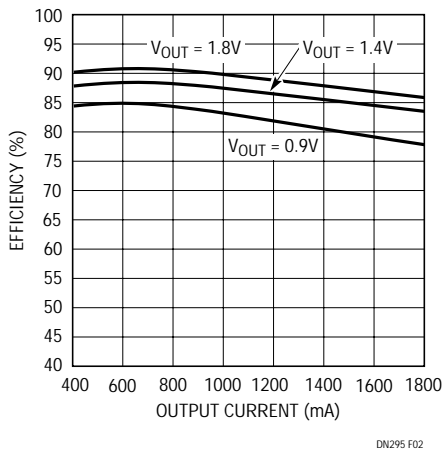

**Figure 2. Efficiencies for the Circuit in Figure 1 where V<sub>IN</sub> = 3.3V**

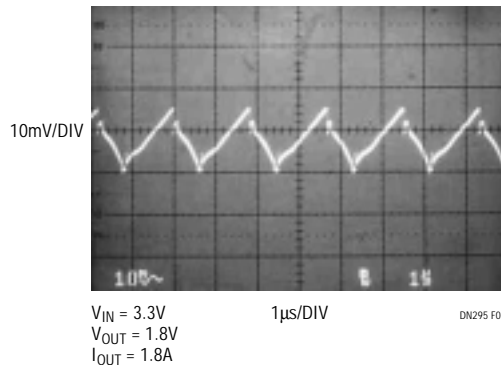

**Figure 3. Output Voltage Ripple for the Circuit in Figure 1**

**Data Sheet Download**

<http://www.linear.com/go/dnLTC1773>

For literature on our Regulators,  
call **1-800-4-LINEAR**. For applications help,  
call (408) 432-1900, Ext. 2759